

EKM METERING

EKM-353EDM-N v.2, EKM-354EDM-N v.2

THREE-PHASE DIN-RAIL EXTERNAL CT ELECTRONIC METER INSTRUCTIONS

I. The functions of the product meet all the technical requirements of three phase electronic meter IEC 62053-21 and IEC 62052-11 standards (static AC active power meter).

II. Functions and characteristics

- 1: Active electricity measuring, without adjustment under long-term functioning.
- 2: With RS485 communication, index in accordance with IEC 62056-21(A mode), which focuses on convenient intelligent management conveniently.
- 3: Wide work temperature range: -30—70°C

III. Technical specifications

1. Rated voltage: 3*208V, 3*240V, 3*480V
2. Rated current: 5(200)A
3. Impulse constant: 800imp/kWh
4. Rated frequency: 50Hz/60Hz
5. Class of Accuracy: 0.5
6. Start current: 0.4%I_b(1.0)
7. Power consumption: ≤1W (when 220V 20A)
8. Accuracy (see the form bellow)

Load current	Power factor COS Φ	Basic error%		
		Class 0.5	Class 1	Class 2
0.05I _b	1.0	±1.0	±1.5	±2.5
0.1I _b ~I _{max}	1.0	±0.5	±1.0	±2.0
0.1I _b	0.5(L)	±1.0	±1.5	±2.5
	0.8(C)	±1.0	±1.5	—
0.2I _b ~I _{max}	0.5(L)	±0.5	±1.0	±2.0
	0.8(C)	±0.5	±1.0	—

9. Important!! Meters that are supplied with split-core current transformers (CTs) are matched and tested with the included CTs. Using any other CT with these meters will void the warranty. Accuracy will be decreased.

10. Environment condition: standard work temperature -20—60°C
limit work temperature -30—70°C
relative humidity ≤85%

11. Weight: 0.32kg
12. Outside dimensions: 78×100×65mm

IV. Working principle

See Fig.1. When the energy meter is working, the energy consumed by the user is transformed into voltage and current signals, sampled by sample circuits respectively each phase could mutually plus by specialized IC, well then we get the power of whole phase, A pulse signal is then produced by a specialized IC. The pulse signal is directly proportional to power consumption. The MCU records and stores the corresponding energy use. The LCD displays the energy use. Recorded information and data can be transferred by the RS485 communication interface.

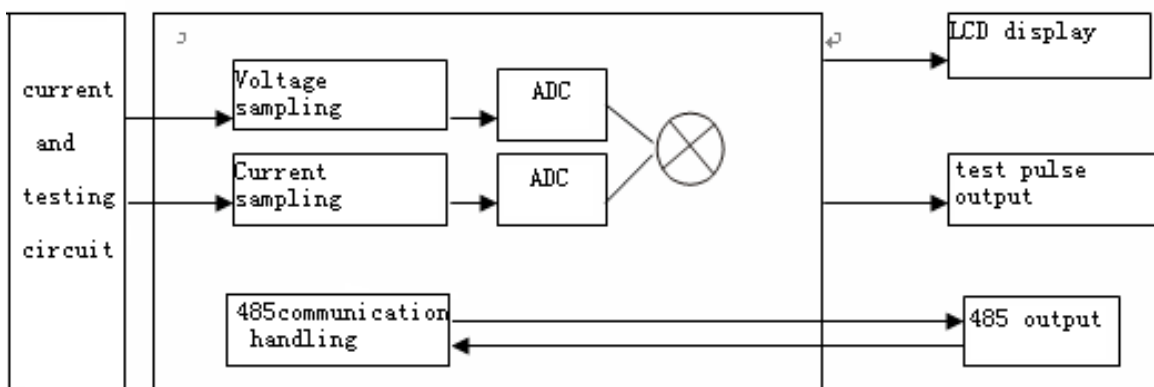

Fig. 1

1. The meter is tested and sealed before leaving the factory.
2. The meter should be installed in a meter enclosure whether indoors or outdoors. The meter should be installed on a solid and fire-resistant backing, and not near any combustible, corrosive or noxious substances or gases.

3. **WARNING!!** Disconnect or switch off power before attempting to install the meter! Only install, connect, disconnect or service the meter or the current transformers (CTs) with all **POWER DISCONNECTED!!**
4. The meter should be connected in accordance with the wiring diagram on the meter case. Copper wiring is preferred.
5. For three-wire meters, the LCD display shows 12 items: Total electricity consumption, reverse electricity consumption, L1, L2, L3 voltage, L1, L3 current, L1, L3 total power and L1, L3 COS ϕ , five seconds by turns between every item.
For four-wire meters the LCD display shows 15 items: Total electricity consumption, reverse electricity consumption, L1, L2, L3 voltage, L1, L2, L3 current, L1, L2, L3 total power, L1, L2, L3 phase COS ϕ , five seconds by turns between every item
6. The meter provides data for maximum demand(kW) and after setting, it can calculate maximum demand for the following time periods: 15minutes, 30minutes, 60minutes.
7. The meter has four tariffs(T1,T2,T3,T4) to calculate the power at different periods of time, and it can set 4 time periods at most, per day, and specify the number of the tariff for that period(from T1 to T4) And the meter time can be set by RS-485 communication.

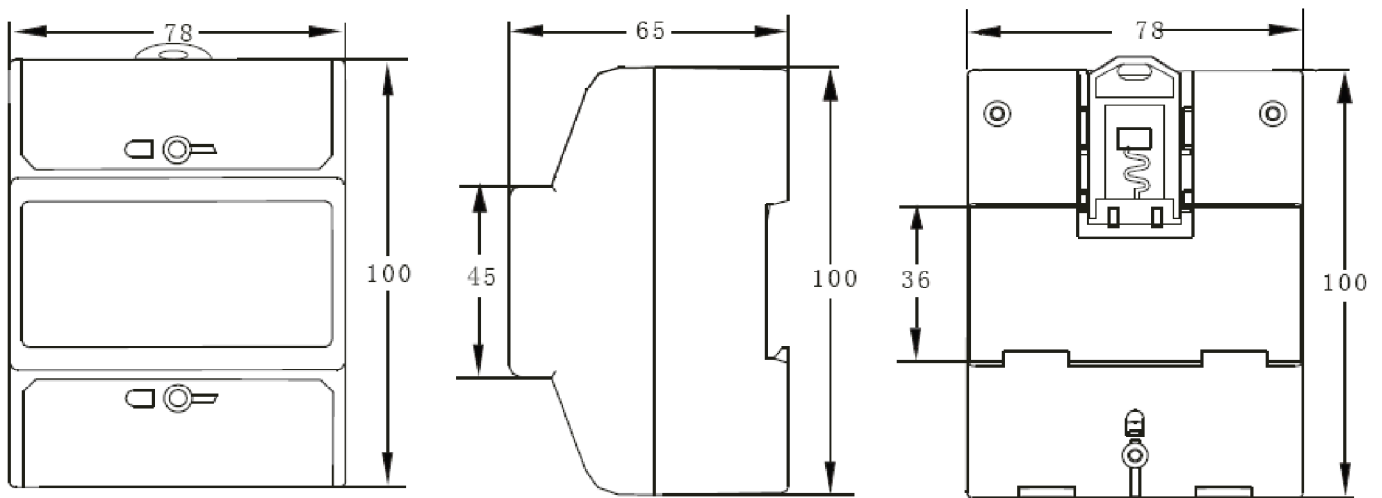

Fig. 2

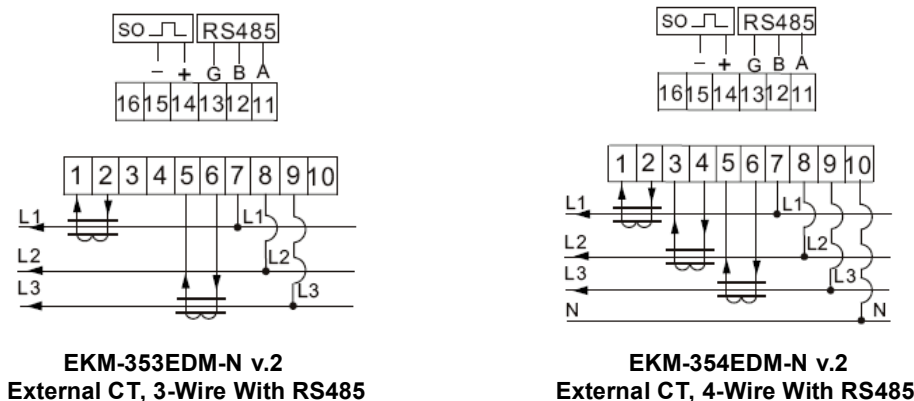

Fig.3

V. Transportation and handling

1. The meter shall not be subjected to throwing, dropping, kicking or other physical abuse, as there are high precision components inside that will break or make the meter measure inaccurately. The process of transportation, handling and installation should be according to transportation and storage rule of GB/T15464-1995.
2. Keep the meter in the original package when stored. The storage temperature range should be 0—40°C. relative humidity $\leq 85\%$. There should be no toxic or corrosive substance or gases in the air.
3. The meters shall be stacked on the platform in storage. Don't stack more than 10 units high.
4. Time limit of guarantee.
Within 18 months from the day of sale, and on the condition that the user abide by the specifications and installation procedures, and the sealing is kept completely intact. If the meter does not correspond with the rule of the enterprise standard, the meter shall be repaired free or replaced.